

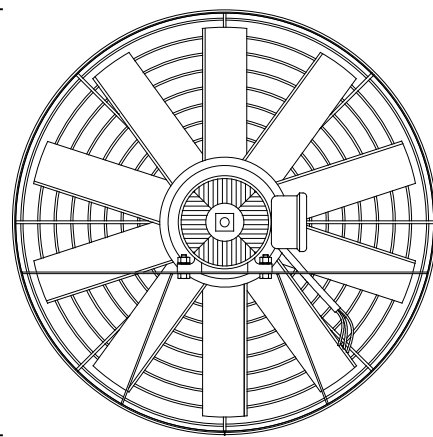

## Exaustor EQ1000T8

OBS. DESENHOS ILUSTRATIVOS

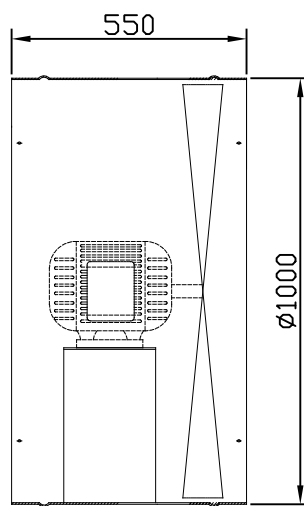

ESQUEMA DE LIGAÇÃO  
VIDE PLAQUETA DO MOTOR

CURVA CARACTERÍSTICA  
(20°C/760 mm Hg)

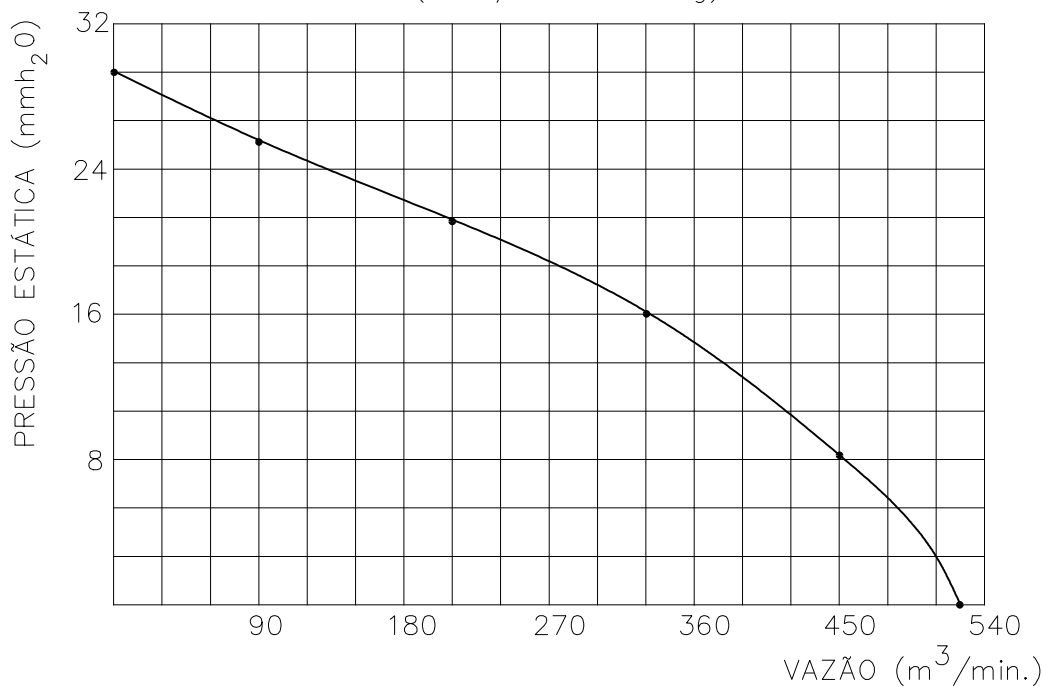

Todos os valores registrados neste folheto estão sujeitos a alterações sob critério do fabricante sem prévio aviso.

CÓPIA NÃO CONTROLADA

Qualitas Indústria Eletromecânica Ltda.

Av. Anésio Bazani, 240 Jardim Progresso Itapira-SP CEP-13973-532

Fone 19 3913-9300 - Fax 19 3913-9309 [www.qualitas.ind.br](http://www.qualitas.ind.br)

