

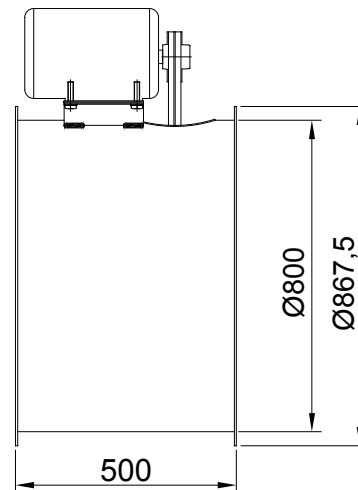

Exaustor  
EQ800TRT6

OBS. FOTO E DESENHOS ILUSTRATIVOS

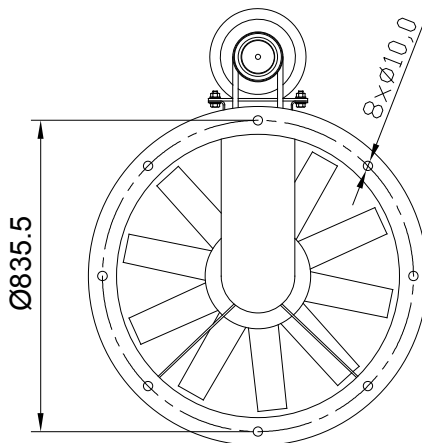

CURVA CARACTERÍSTICA  
(20°C/760 mm Hg)

ESQUEMA DE LIGAÇÃO  
VIDE PLAQUETA DO MOTOR

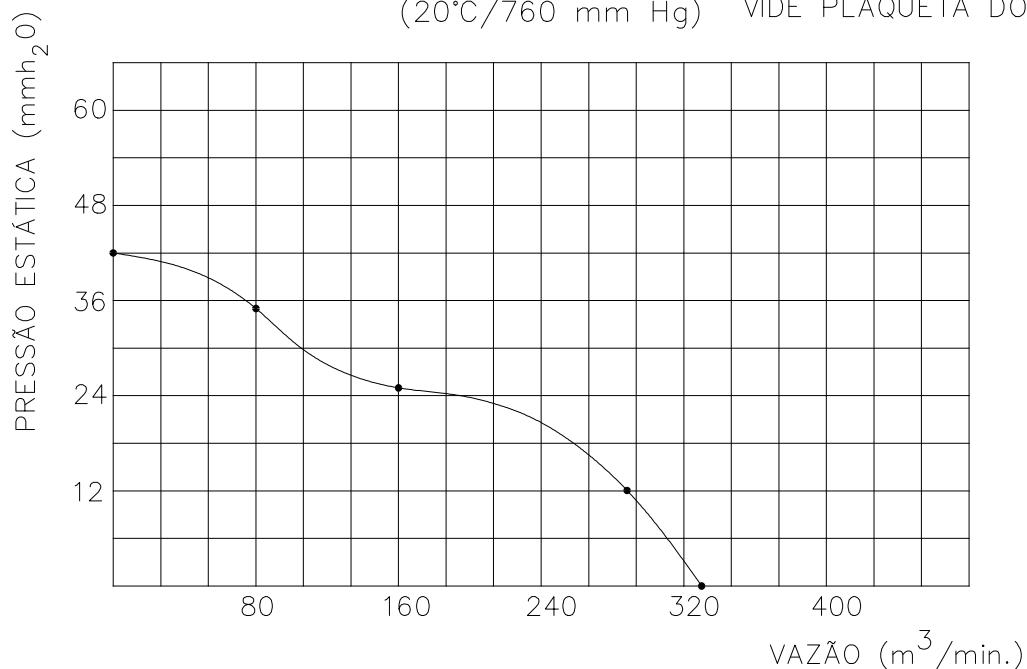

Todos os valores registrados neste folheto estão sujeitos a alterações sob critério do fabricante sem prévio aviso.

CÓPIA NÃO CONTROLADA

